

HOW TO INSTALL

REPLACEMENT HYDRAULIC ASSEMBLY FOR SL-10 SERIES LOAD BARS

These instructions for installing Replacement Hydraulic Assembly for SL-10 Series Load Bars are intended to be a general guide to help the installer. Modifications to the Load Bars may be required. Any modifications are at the discretion, responsibility and risk of the installer.



TOOLS NEEDED

- 5/8" 12pt Socket
- Phillips-Head Screwdriver
- Flat-Head Screwdriver
- 1/8" & 1/4" Roll Pin Punch (available for purchase)
- Hammer (preferably brass to decrease likelihood of damage to bar)
- Pliers

PARTS DEFINITIONS

- Power Rod - The end that extends when handle is pumped
- Extension Tube - The end that can be adjusted with the silver snap button
- Hydraulic Assembly - Includes: cylinder tube, pump body, black bladder tube, cradle, and end guides

NOTE: The cradle and larger end guides are used for SL-10 bars with 1.75" main extension tubes. The smaller end guides are used for bars with 1.25" main extension tube.

IDENTIFY YOUR TUBE SIZE

Older SL-10 bars have a smooth main square tube size of 1.25". SL-10 bars in current production measure 1.75" square main tube with grooves.

Verifying Hydraulic Failure

Prior to replacing hydraulic, check the following:

1. Be sure the bar is completely compressed. If the power tube is extended press the release button and push on the power tube until it is completely compressed.
2. With the power rod end of bar up and the adjustable extension tube on the bottom, pump the handle to see if the bar will pump. If the power tube end does extend, pump 8-10 times. Then take your hand and try to push the foot of the power rod end to see if it will compress. If it does not move, the hydraulic is functioning properly. Now, press the release button to see if the hydraulic pressure is released. If you push the button and are able to compress the bar, the hydraulic is functioning properly and should not be replaced.
3. If you pump the handle and the power rod does not move or it appears to skip, check the nose of the pump handle by removing the pump handle. If the nose is worn it should be replaced. This worn handle can be the problem rather than the hydraulic. It is recommended the handles be replaced at least every 12 to 18 of moderate use.
4. If you are able to pump the hydraulic, but are unable to release the bar, check the release button by removing the release button. If the little plunger of the release button has been broken off, the bar will not release and the release button should be replaced. This broken release button can be the problem rather than the hydraulic.

Once you have checked the bar and determined that the hydraulic is not working, follow the instructions to remove failed hydraulic assembly.

Removing Failed Hydraulic Assembly

Important: The load bar **MUST** be positioned at its smallest length.

1. Place power rod end on ground. Press red release button. Push down on bar until completely compressed.
2. Place extension tube end on ground. Press silver snap button. Slide the bar down past snap button until completely shortened.

OVER

HOW TO INSTALL

REPLACEMENT HYDRAULIC ASSEMBLY FOR SL-10 SERIES LOAD BARS

3. Remove two roll pins on the end of the bar:

- Place bar on level surface.
- Using hammer and roll pin punch, drive pins completely out of the bar.

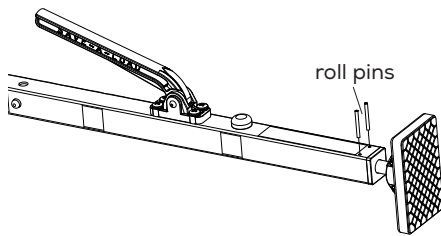

NOTE: Older models may use screws rather than roll pins.

4. Remove red release button:

- Use flat head screwdriver to pry up button cover.
- Use pliers (or 5/8" socket on ridged button) in a counter-clockwise motion to loosen release button.
- Unscrew release button and remove.

NOTE: Release button may be smooth or ridged based on the date of production. A 5/8" socket may be required to loosen.

- ### 5. Remove handle using a Phillips screwdriver to remove the four screws on the handle assembly. A flat head screwdriver may be needed to release the bracket from the bar.

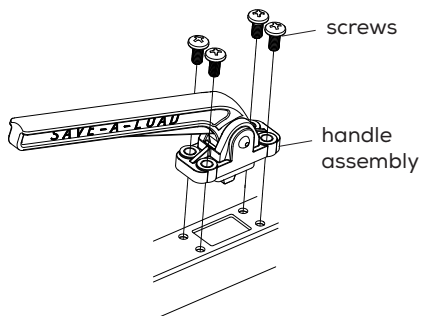

6. Remove hydraulic assembly:

- Pull on the power rod end to slide the hydraulic unit out.

IMPORTANT: Hydraulic fluid may leak during this step. Hold over a sink or pan.

- Grasp the silver cylinder tube and the foot attached to the power rod and pull apart. The power rod will come out of the cylinder tube.
- Discard old hydraulic.

Installing New Hydraulic Assembly

- Determine if your power rod has a seal installed on the end. If your power rod is an older model, the seal must be removed before assembling the new hydraulic assembly.

Remove seal if applicable



- Insert power rod into new cylinder tube.
- If your SL-10 Main Tube is 1.25" square, align the end guide orienting holes in guide with holes in bars. If your SL-10 Main Tube is 1.75", use the larger end guides and cradle. Confirm the small half of the end guide is oriented to the handle and button side of the bar (top of bar).
- Align rectangular hole on the top of the bar in the same direction as the rectangular hole in the hydraulic assembly and slide back into the main tube the same way it came out.

Reassemble the Bar

- Align rectangular opening of pump body with rectangular opening in the main tube.
- Check roll pin holes to make sure there is no obstruction. If the holes are obstructed, this means the end guide is either not oriented correctly or has come out of bar end.
- Drive both roll pins back into bar until flush.
- Reinstall handle assembly by aligning rectangle area of pump body with rectangle hole in bar and pump assembly. Tighten all 4 screws.
- Insert release button plunger side down, and screw on hand tight and snug with pliers or 5/8" socket.
- Slide button to cover onto release button.