

# FLEET ENGINEERS

1800 EAST KEATING AVENUE  
MUSKEGON, MI 49442  
PH: 1-800-333-7890 • F: 231-777-2720

Installation Sheet #INS-02021

## ISO-BLOX®

### Installation Instructions

Patent 6,648,373

**The ISO-BLOX™ is a vibration isolation system designed for use under the fender to secure a 1-7/8" tube mount in flat or center mounted applications.**

NOTE: These instructions for installation are intended to be a general guide to help the installer. Because of the large number of possible mounting configurations, the installer is responsible for the ultimate installation design. Any modifications to the product are at the discretion, responsibility and risk of the installer.

#### Each X-FLEX® ISO-BLOX® System Includes:

- (4) Vibro-Isolators
- (4) Mounting Clamp Plates
- (8) 5/16-18x3/4 S.S. Truss Head Self Locking Screws
- (8) 5/16-18x3/4 Hex Head Bolts
- (8) 5/16 Lock Washers



1. Position the two ISO-BLOX between the fender and mounting tube. Make sure the fender, ISO-BLOX and mounting tube are all in the desired location to spot the mounting holes.

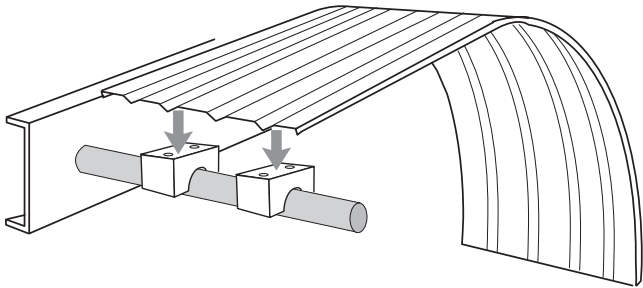

NOTE: The desired position for the X-FLEX mounts will vary from one installation to another. This is best determined with the help of the instructions from the fender manufacturer.

If mounting instructions from the fender manufacturer are unavailable, the X-FLEX mounts should be located approximately 5"-6" in from the sides of the fender. When using X-FLEX ISO-BLOX with an end mount on a half tandem, locate no more than 18" from the end of the fender.

2. Using a spotting punch or 1/4" maximum diameter drill bit, spot where the mounting holes will be in the fender by running the drill bit through the threaded bushings in the ISO-BLOX. Be careful not to damage the threaded bushings.

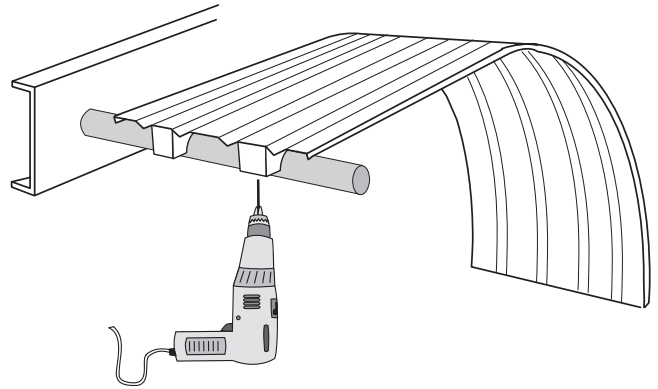

NOTE: Running the drill in reverse is a safe way to do this!

3. Remove the fender and drill 11/32" to 3/8" diameter holes using the spot marks for location.
4. Reposition and loosely assemble the fender to the Vibro-Isolators with the 5/16" x 3/4" self locking stainless steel truss head screws.

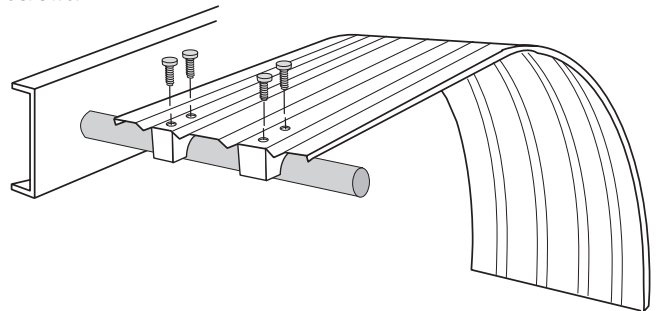

5. On the underside of the fender, loosely assemble the clamping plates to the ISO-BLOX with the 5/16" x 3/4" hex head bolts and lock washers.

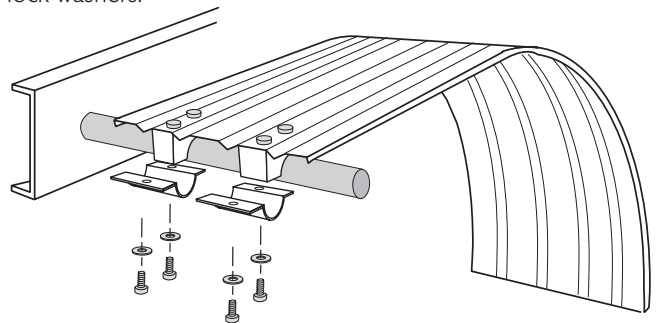

6. Install the other fender mounts using the same procedure or, if using a different style of fender mount, use manufactures directions.
7. When the ISO-BLOX® and any other mounts are installed and the fender is in the desired location, tighten all screws and bolts on the ISO-BLOX® to proper torque:

**5/16" bolts and screws torque to 156 in. lbs. or 13 ft. lbs.**