

THE STEV®

THE "SENSING" TRAILER EMERGENCY VALVE PROVIDES SERVICE RESERVOIR PRIORITY LOGIC

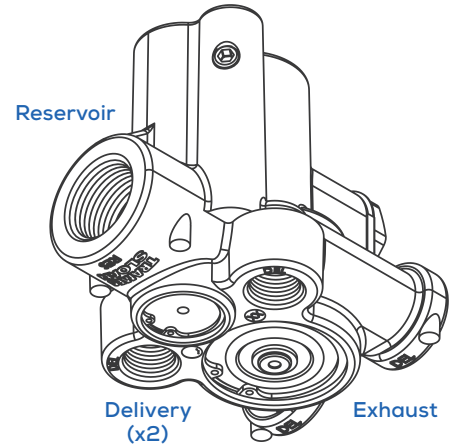
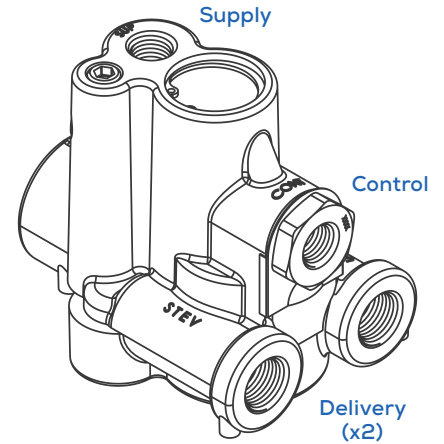

EXCLUSIVE STEV FEATURES & BENEFITS

Tramec Sloan's "Sensing" Trailer Emergency Valve (STEV) Provides service brake priority to assure adequate supply is available from the tractor. The logic of the STEV assures that the trailer parking brakes will not release before there is sufficient air pressure in the reservoir to apply service brakes.

- Provides Trailer Spring Brake Control and Gladhand Pressure Protection as Required by DOT 121
- Prevents Spring Brake Drag
- **Sealed Hard Anodized Finish – 200+ Hours Salt Spray Resistance**
- Use a Single Air Tank: Allows the Elimination of the Protected Reservoir
- Small Size is Gentle on Tanks, Weigh Less than Two Pounds
- Easy Installation & Conversion from Old Systems
- Fully Compatible with Anti-Lock Systems

THE STEV® REPLACES:

Haldex KN26110
Sealco 110700

P/N	DESCRIPTION	SUPPLY PORT	CONTROL PORT	RESERVOIR PORT	DELIVERY PORTS (x4)
51321	STEV Assembly	1/4"-18	1/4"-18	3/4"-14	3/8"-18
51322	STEV Assembly	3/8"-18	3/8"-18	1/2"-14	3/8"-18
51325	STEV Rebuild Kit	-	-	-	-

THE STEV[®] "SENSING" TRAILER EMERGENCY VALVE

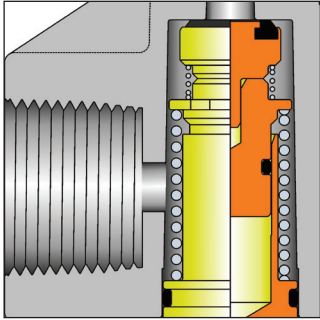

PRESSURE PROTECTION: When the supply line pressure exceeds 85 psi, the piston shifts down to allow flow to the tank. The check valve retains tank pressure when the gladhand is vented.

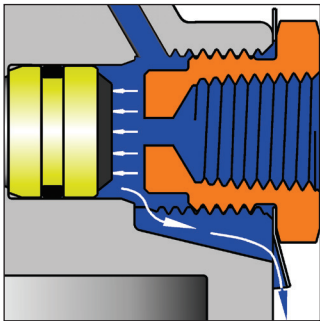

VENTING ANTI-COMPOUNDING: When the spring brakes are on, the control line is vented to atmosphere. This prevents false release of spring brakes on doubles and ejects fluids trapped in control lines.

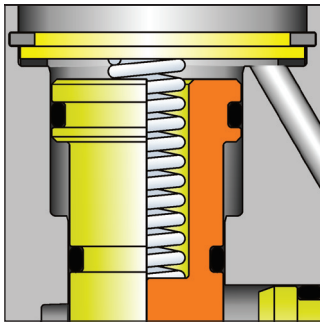

RESERVOIR SENSOR: The reservoir sensor section measures the tank pressure and prevents air from flowing into the spring brakes before service braking capability builds in the system.

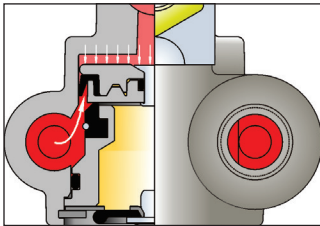

By design, the spring brakes will retain the maximum pressure delivered by the compressor, until the supply gladhand pressure drops to about 35 psi. The effective area of the shuttle at gladhand pressure is about 3 times that of the area exposed to spring brake pressure.

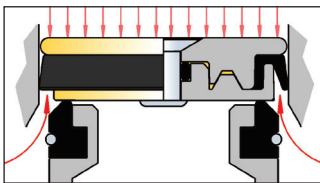

Area X Pressure = the Force to Retain or Exhaust the pressure in the spring brakes.

RESERVOIR CHARGING:

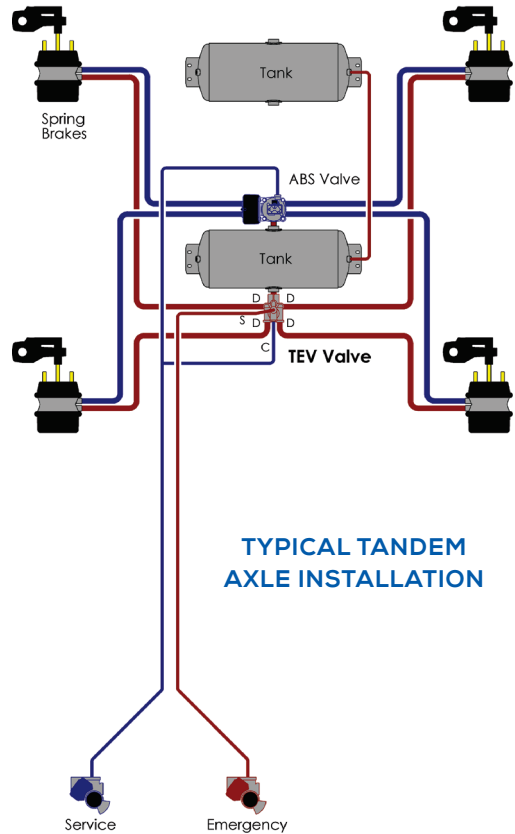
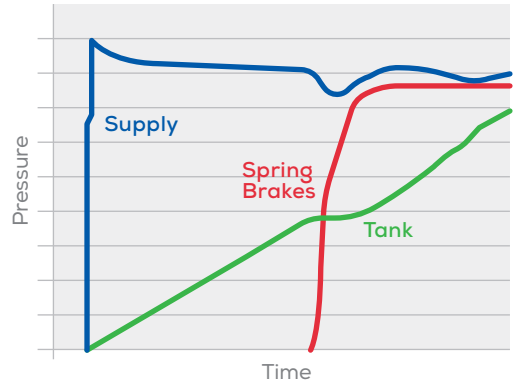

TYPICAL TANDEM AXLE INSTALLATION