

## HOW TO INSTALL MASTER MULTI-MOUNT

These instructions for installing Master Multi-Mount are intended to be a general guide to help the installer. Because of the large number of possible mounting configurations, the installer is responsible for the installation design and for providing adequate clearance around the tire carrier (i.e. tire clearance, trailer clearance, etc.). This product may not fit all truck models or types of suspensions. Check truck or trailer manufacturer for suspension travel specifications. Modifications to the brackets and/or the fenders may be required. Any modifications are at the discretion, responsibility and risk of the installer.

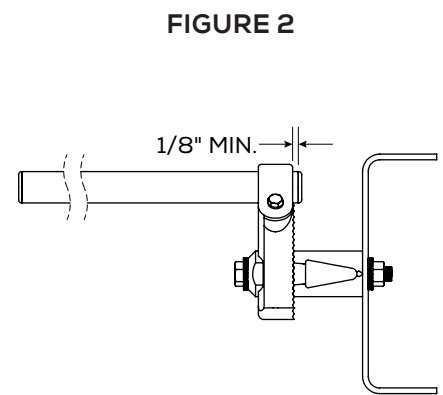
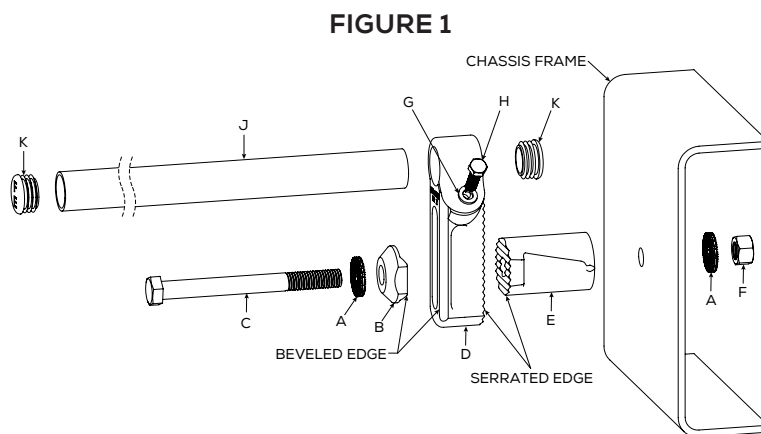

### COMPONENTS

- (A) Nord-Lock Washer
- (B) Master Multi-Mount Casting Washer
- (C) 5/8" x 6 1/2" Bolt
- (D) Master Multi-Mount
- (E) Master Multi-Mount Frame Spacer
- (F) Nut
- (G) 3/8" Lock Washer
- (H) 3/8" x 1-1/4" Bolt
- (J) Master Multi-Mount Tube
- (K) End Caps

1. Place Nord-Lock washer and Master Multi-Mount casting washer as shown in **FIGURE 1** with the side with the bevels facing away from the bolt head onto a 5/8" x 6 1/2" bolt.
2. Insert the bolt assembled in step 1 through the slot in the Master Multi-Mount matching the side with the bevels to the bevels on the washer.
3. Slide the Master Multi-Mount Frame Spacer over the bolt, making sure that the serrations of the two parts engage.
 

**NOTE:** If additional distance from the frame is needed, it can be gained by using the 3.5" extension set (part #031-01299), not included.
4. Insert the bolt through the selected hole in the frame, installing a Nord-Lock washer and a nut onto the bolt. Finger tight at this time.
5. Put a 3/8" lock washer on a 3/8" x 1-1/4" bolt and thread it into the clamp portion of the Master Mount.
6. Slide the Master Multi-Mount Tube through the clamp making sure at least 1/8" of the tube protrudes out the other side, as shown in **FIGURE 2**.
7. Make the desired adjustment for offset and rotational position of the Master Multi-Mount. Tighten the bolts to the proper torque, 210 ft. lbs. for the 5/8" bolt and 23 ft. lbs. for the 3/8" bolt.
- 8) Install an end cap into each end of the Master Multi-Mount tube per directions supplied.